

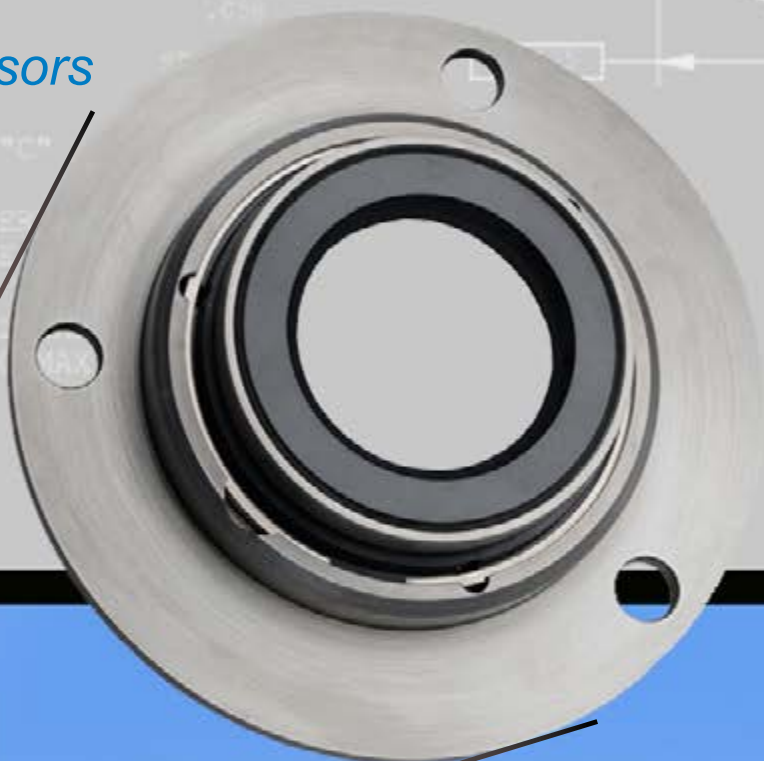

The **NEW Gearbox Output SundSEAL™**
For Sundyne Integrally
Geared Pumps & Compressors

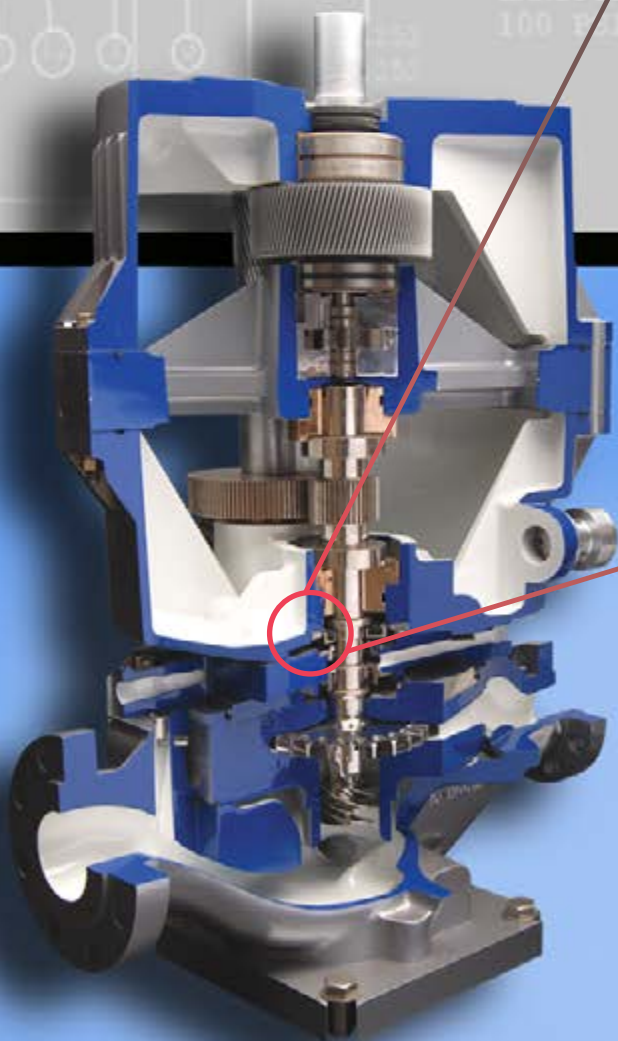

LMV
LMC
BMC

- Increased MTBR
- For Low or High-Speed Service
- Reduced Leakage
- Lower Contact Face Temperatures
- Reverse Pressure Capability
- Easy to Maintain

**RELIABILITY
REALIZED.**

Highly Improved

Typical seals can cause excessive leakage. The NEW proprietary, easy-to-upgrade Gearbox Output SundSEAL from Sundyne is proven to reduce leakage. With proper lubrication and system pressure management, this new seal vastly improves overall operational efficiency and delivers higher MTBR.

Why Sundyne Seals?

SundSEAL uses the latest Sundyne technology to extend reliability. Specifically designed for use with Sundyne integrally geared pumps and compressors, the seal minimizes leakage and increases MTBR. Manufactured from Sundyne proprietary materials, this is our most durable seal to date; and with a straightforward retrofit capability, SundSEAL is an easy upgrade for existing units.

▶
The Gearbox Output SundSEAL minimizes leakage while effectively controlling seal face condition.



The Basics

Gearbox output seals are made to keep lubricant inside the unit, with the seal's stationary and dynamic components coming together to create a mechanical seal. In making contact with each other, these dual parts keep lubricant where it needs to be. Sundyne has specifically designed the SundSEAL to minimize leaks, while also effectively controlling seal face condition. This is the ideal seal design, providing improved performance, reverse pressure capability and longer part life.

Plus – due to its straightforward installation process, SundSEAL output seals can be integrated with your process quickly in the field, without the need to ship your pump to our factory for an upgrade.

Improved Port Design For Optimal Drainage & Pressure Management:



▶
This is a Sundyne engineered upgrade.

Added Gearbox Protection

With its reverse pressure capability, the SundSEAL offers a competitive advantage over existing face lift-off seals. The SundSEAL creates a barrier between the process seals and the gearbox interior that is strong enough to withstand pressure up to 275 PSI providing protection and reliability by keeping process fluid out of your gearbox. In the event of a process seal failure, the SundSEAL will increase equipment reliability and reduce downtime.

Optimize Performance

Over three years of development went into the SundSEAL design, during which time we created a new port design for optimal drainage and pressure management around the SundSEAL contact face. The lower gearbox housing now features three additional passage ways that connect the oil sump area to the SundSEAL. This extra routing improves the seal's ability to control oil leakage by reducing seal face separation force.

This lower gearbox housing modification will optimize SundSEAL's performance, but it is not mandatory for operation. The leakage results published in this brochure were measured without the modification.

New 4-hole housing or easily upgrade your existing equipment

■ Current State
■ NEW Upgrades

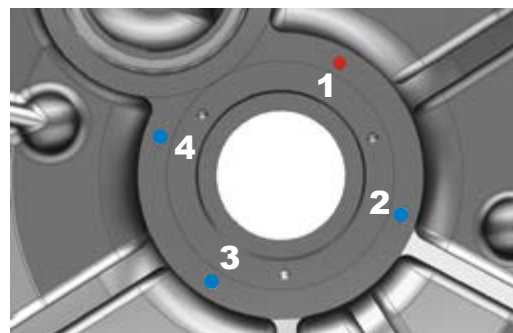

Performance.

Gearbox Output SundSEAL Oil Leakage At 33,915 RPM

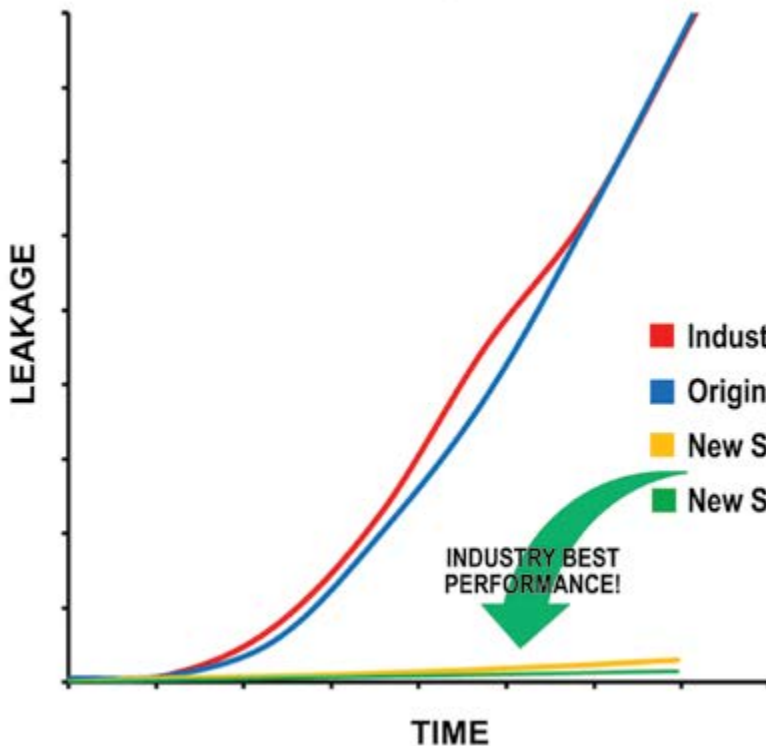

- Industry Standard Mechanical Seal
- Original Sundyne Mechanical Seal SE04AA53G
- New SundSEAL for speeds below 20,000 RPM SE04AA98A
- New SundSEAL for speeds above 20,000 RPM SE04AA99A

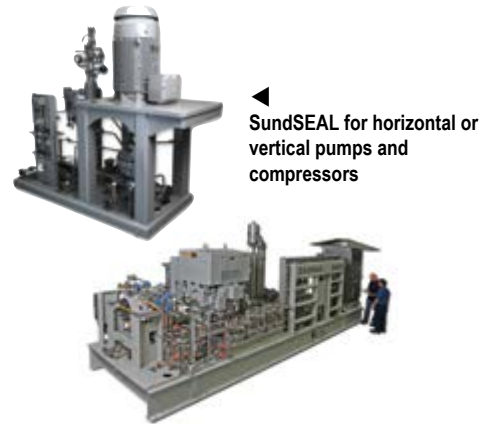

Seal Validation Program With Multiple Test Rigs

Factory Tested For Multiple Variables

Sundyne understands that a great seal needs to maintain its seal interface geometry to avoid excessive leakage. The Gearbox Output SundSEAL is specifically designed to minimize leakage while effectively controlling seal face condition for a longer, more durable life. The new seal comes with over 20,000 hours of combined factory and lab testing behind it so you can count on its dependable performance in even the most challenging applications.



Field-proven performance, with hundreds of SundSEAL installations in critical services around the world.

- ✓ Speed tested: 5802 RPM 14738 RPM 22831 RPM 33915 RPM
- ✓ Cooling water inlet temp uniform between test rigs (all duration testing performed with sump oil at 160 °F (+/- 5 degrees))
- ✓ Pressure management variants and temperature tested
- ✓ Mineral and synthetic oil blends tested
- ✓ Start-stop cycle testing at highest output speed of 33,915 RPM
- ✓ High vibration (+.3 in/sec) implemented and evaluated
- ✓ Multiple seal face substrates and design variables tested

NOW IT'S EASIER THAN EVER TO UPGRADE YOUR SEALS!

Product Development

In effort to reduce leakage and prolong seal life over existing market options, two new gearbox output seals are available.

The mechanical design and material selection are specifically engineered for the Sundyne gearbox and are optimized based on output speed. Each seal is packaged into a kit containing one SE04AA9XA stationary seal and one RJ09AXXSN1HN00 mating ring. Three kits cover all applicable pump, compressor, and unique configured gearboxes:

A Legacy Of Quality

Our factories around the world have been manufacturing highly reliable compressors and pumps for over sixty years, engineering each shipped unit to meet the highest quality and most rigorous industry standards.

Give us your toughest application requirements and we'll custom tailor a solution to fit your needs today. We NEVER say never!

KT01SE98A0 Low-RPM Seal Kit

- Output speed ≤ 20,000-RPM
- 275-PSI (19-bar) reverse pressure capability
- Contains SE04AA98A and RJ09AA41SN1HN00

KT01SE98A1 Low-RPM Seal Kit (high-flow pump models only)

- Output speed ≤ 20,000-RPM
- 275-PSI (19-bar) reverse pressure capability
- Contains SE04AA98A and RJ09AK16SN1HN00

KT01SE99A High-RPM Seal Kit

- Output speed > 20,000-RPM
- 150-PSI (10.3-bar) reverse pressure capability
- Contains SE04AA99A and RJ09AA41SN1HN00



The "A" suffix character specifies a combination of optimal seal face materials, fluorocarbon o-ring, and stainless steel metal components; appropriate for all services.

	MODEL	OUTPUT SPEED ≤ 20,000 RPM	OUTPUT SPEED > 20,000 RPM
PUMP	311 / 312 / 316	KT01SE98A0	KT01SE99A
	321 / 322	KT01SE98A0	N/A
	High Flow: 313 / 333	KT01SE98A1	N/A
	331 / 336 331N / 336N	KT01SE98A0	KT01SE99A
	High Flow: 338	KT01SE98A1	N/A
COMPRESSOR	31X / 33X / 34X	KT01SE98A0	KT01SE99A
UNIQUE CONFIGURATION	LMG-330L	KT01SE98A0	N/A



**RELIABILITY
REALIZED.**

Visit our website at: www.sundyne.com

Sundyne, LLC 14845 W. 64th Ave. Arvada, CO 80007 USA 1-866-SUNDYNE (US and Canada), Ph: +1 303 425 0800 Fax: +1 303 425 0896

Sundyne China Building 1, No. 879 Shen Fu Road, XinZhuang Industrial Zone, Min Hang District, Shanghai, China 201108, Ph: +86 21 5055 5005 Fax: +86 21 5442 5265

Sundyne International S.A. 13-15, Bld. Eiffel - B.P. 30 21604 Longvic Cedex France Ph: +33 (0)3 80 38 33 00 Fax: +33 (0)3 80 38 33 66

Sundyne Marelli Bombas, S.R.L. Ctra. Madrid-Toledo, Km.30.8 45200 Illescas Toledo, Spain Ph: +34 925 53 45 00 Fax: +34 925 51 16 00

Sundyne HMDKontro Sealless Pumps, Ltd. Marshall Rd Hampden Park Industrial Estate Eastbourne East Sussex, BN22 9AN UK Ph: +44 1323 452000 Fax: +44 1323 503369

© 2016 Sundyne, LLC All rights reserved. Logos and trade names are property of their respective owners. Gearbox Output SundSEAL Brochure_US_v2.0 082616; POD